



INSTYTUT TECHNIKI BUDOWLANEJ
PL 00-611 WARSZAWA
ul. Filtrowa 1
tel.: (+48 22) 825-04-71
(+48 22) 825-76-55
fax: (+48 22) 825-52-86
www.itb.pl



Member of



www.eota.eu

European Technical Assessment

**ETA-13/0584
of 24/09/2014**

General Part

Technical Assessment Body issuing the European Technical Assessment

Instytut Techniki Budowlanej

Trade name of the construction product

R-DCA, R-DCA-A4 and R-DCL Wedge Anchors

Product family to which the construction product belongs

Steel deformation-controlled expansion anchors in sizes of M6, M8, M10, M12, M16 and M20 for multiple use for non-structural applications in concrete

Manufacturer

RAWLPLUG S.A.
ul. Kwidzyńska 6
51-416 Wrocław
Poland

Manufacturing plant(s)

Manufacturing Plants no. 6 and 7

This European Technical Assessment contains

10 pages including 3 Annexes which form an integral part of this assessment

This European Technical Assessment is issued in accordance with Regulation (EU) No 305/2011, on the basis of

Guideline for European Technical Approval ETAG 001, Edition April 2013 "Metal anchors for use in concrete – Part 1: Anchors in general and Part 6: Anchors for multiple use for non-structural applications", used as European Assessment Document (EAD)

This version replaces

ETA-13/0584 issued on 27/06/2013

This European Technical Assessment is issued by the Technical Assessment Body in its official language. Translations of this European Technical Assessment in other languages shall fully correspond to the original issued document and should be identified as such.

Communication of this European Technical Assessment, including transmission by electronic means, shall be in full. However, partial reproduction may be made, with the written consent of the issuing Technical Assessment Body. Any partial reproduction has to be identified as such.

Specific Part

1 Technical description of the product

The R-DCA, R-DCA-A4 and R-DCL Wedge Anchors are deformation-controlled expansion anchors in sizes of M6, M8, M10, M12, M16 and M20. The anchors R-DCA and R-DCL are made from galvanized steel and R-DCA-A4 are made from stainless steel.

The anchor is installed in a drilled hole and anchored by deformation-controlled expansion.

The description of the product is given in Annex A1.

2 Specification of the intended use in accordance with the applicable EAD

The performances given in Section 3 are only valid if the anchors are used in compliance with the specifications and conditions given in Annex B1 to B3.

The performances given in this European Technical Assessment are based on an assumed working life of the anchor of 50 years. The indications given on the working life cannot be interpreted as a guarantee given by the producer or the Technical Assessment Body, but are to be regarded only as a means for choosing the right products in relation to the expected economically reasonable working life of the works.

3 Performance of the product and references to the methods used for its assessment

3.1 Performance of the product

3.1.1 Mechanical resistance and stability (BWR 1)

Essential characteristic	Performance
Characteristic resistance for all load directions	See Annex C1
Edge distances and spacing	See Annex C1

3.1.2 Safety in case of fire (BWR 2)

Essential characteristic	Performance
Reaction to fire	Anchors satisfy requirements for Class A1
Characteristic resistance under fire exposure	See Annex C2

3.1.3 Hygiene, health and the environment (BWR 3)

Regarding the dangerous substances clauses contained in this European Technical Assessment, there may be requirements applicable to the products falling within its scope (e.g. transposed European legislation and national laws, regulations and administrative provisions). In order to meet the provisions of the Construction Products Regulation, these requirements need also to be complied with, when and where they apply.

3.1.4 Safety in use (BWR 4)

For Basic Requirement Safety in use the same criteria are valid as for Basic Requirement Mechanical resistance and stability (BWR 1).

3.1.5 Sustainable use of natural resources (BWR 7)

No performance determined.

3.2 Methods used for the assessment

The assessment of fitness of the anchors for the intended use in relation to the requirements for mechanical resistance and stability and safety in use in the sense of the Basic Requirements 1 and 4 has been made in accordance with the ETAG 001 "Metal anchors for use in concrete", Part 1: "Anchors in general" and Part 6: "Anchors for multiple use for non-structural applications".

The assessment of the anchor for the intended use in relation to the requirements for resistance to fire has been made in accordance with the EOTA Technical Report TR 020 "Evaluation of anchorages in concrete concerning resistance to fire".

4 Assessment and verification of constancy of performance (hereinafter AVCP) system applied, with reference to its legal base

According to Decision 97/161/EC of the European Commission the system of assessment and verification of constancy of performance (see Annex V to Regulation (EU) No 305/2011) given in the following table applies.

Product	Intended use	Level or class	System
Metal anchors for use in concrete (light-duty type)	For use in redundant systems for fixing and/or supporting to concrete elements such as lightweight suspended ceilings, as well as installations	–	2+

5 Technical details necessary for the implementation of the AVCP system, as provided for in the applicable EAD

Technical details necessary for the implementation of the AVCP system are laid down in the Control Plan which is deposited at Instytut Techniki Budowlanej.

For type testing the results of the tests performed as part of the assessment for the European Technical Assessment shall be used unless there are changes in the production line or plant. In such cases the necessary type testing has to be agreed between Instytut Techniki Budowlanej and the notified body.

Issued in Warsaw on 29/09/2014 by Instytut Techniki Budowlanej

Marek Kaproń
Deputy Director ITB

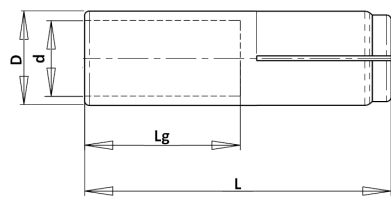

R-DCA and R-DCA-A4 sleeve

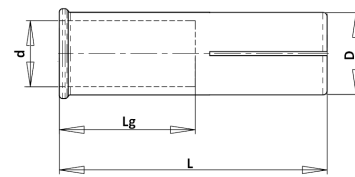

R-DCL sleeve

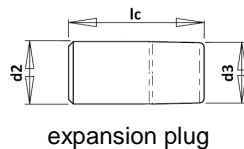

expansion plug

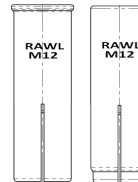

Marking:

Identifying mark – **RAWL**
 Size: Mxx (A4)
 xx – thread size
 A4 – for stainless steel

Table A1. Anchors R-DCA and R-DCL materials and dimensions

R-DCA / R-DCL		M6	M8	M10	M12	M16	M20
Anchor length L	[mm]	25	30	40	50	65	80
Inner diameter d	[mm]	6	8	10	12	16	20
External diameter D	[mm]	8	10	12	15	20	25
Thread length Lg	[mm]	11	13	15	20	25	35
Anchor material	Steel in accordance with ASTM A510, SAE 1008 or SAE 1010; thickness of galvanizing > 5 µm $f_{uk} \geq 450 \text{ N/mm}^2$ and $f_{yk} \geq 360 \text{ N/mm}^2$						
Fastening screw or threaded rod material	Steel, property class ≥ 4.8 according to EN-ISO 898-1; thickness of galvanizing > 5 µm						

Table A2. Anchor R-DCA-A4 materials and dimensions

R-DCA-A4		M6	M8	M10	M12	M16
Anchor length L	[mm]	25	30	40	50	65
Inner diameter d	[mm]	6	8	10	12	16
External diameter D	[mm]	8	10	12	15	20
Thread length Lg	[mm]	11	13	15	20	25
Anchor material	Stainless steel 1.4401 according to EN 10088 (AISI 316) $f_{uk} \geq 500 \text{ N/mm}^2$ and $f_{yk} \geq 210 \text{ N/mm}^2$					
Fastening screw or threaded rod material	Stainless steel 1.4401 in accordance with EN 10088; property class ≥ 70 according to EN ISO 3506					

Table A3. Expansion plug materials and dimensions

Expansion plug		M6	M8	M10	M12	M16	M20
Rear diameter d ₂	[mm]	5,0	6,4	8,0	10,3	13,5	16,8
Front diameter d ₃	[mm]	4,3	5,1	6,8	7,8	13,0	15,2
Length l _c	[mm]	9,8	11,4	16,0	20,8	29,2	30,0
Expansion plug material	Steel in accordance with JISG3505, SWRM8K or SWRM10K; thickness of galvanizing > 5 µm or stainless steel 1.4401 according to EN 10088 (AISI 316)						

R-DCA, R-DCA-A4 and R-DCL Wedge Anchors

Product description
 Characteristic of the product

Annex A1
 of European
 Technical Assessment
 ETA-13/0584

SPECIFICATION OF INTENDED USE

Anchorage subject to:

- Multiple use for non-structural applications: sizes from M6 to M20.
- Static and quasi-static loads: sizes from M6 to M20.
- Anchorages with requirements related to resistance to fire: sizes from M8 to M20 (R-DCA and R-DCL) and sizes from M8 to M16 (R-DCA-A4).

Base material:

- Reinforced or unreinforced normal weight concrete of strength class C20/25 at minimum to C50/60 at maximum according to EN 206.
- Cracked and non-cracked concrete: sizes from M6 to M20 (R-DCA, R-DCL) and M6 to M16 (R-DCA-A4).

Use conditions (environmental conditions):

- R-DCA, R-DCL all sizes (galvanized steel) and R-DCA-A4 size M6 (stainless steel): structures subject to dry internal conditions.
- R-DCA-A4 sizes from M8 to M16 (stainless steel): structures subject to dry internal conditions and also in concrete subject to external atmospheric exposure (including industrial and marine environment) or exposure in permanently damp internal conditions if no particular aggressive conditions exist. Such particular aggressive conditions are e.g. permanent, alternating immersion in seawater or the splash zone of seawater, chloride atmosphere of indoor swimming pools or atmosphere with extreme chemical pollution (e.g. in desulphurization plants or road tunnels where de-icing materials are used).

Design:

- Anchorages are designed under the responsibility of an engineer experienced in anchorages and concrete work.
- Verifiable calculation notes and drawings are prepared taking account of the loads to be transmitted. The position of the anchor is indicated on the design drawings (e.g. position of the anchor relative to reinforcement or to supports, etc.).
- Anchorages under static and quasi-static loads are designed in accordance with ETAG 001, Annex C, design method C, Edition August 2010.
- The design of anchorages under fire exposure has to consider the conditions given in the EOTA Technical Report TR 020.
- Fasteners are only to be used for multiple use for non-structural applications acc. to ETAG 001, Part 6, Edition August 2010.

Installation:

- Anchor installation carried out by appropriately qualified personnel and under the supervision of the person responsible for technical matters of the site.
- Use of the anchor only as supplied by the manufacturer without exchanging any component of the anchor.
- Anchor installation in accordance with the manufacturer's specifications and drawings and using the appropriate tools.
- Check of concrete being well compacted, e.g. without significant voids.
- Positioning of the drill holes without damaging the reinforcement.
- In case of aborted hole: new drilling at a minimum distance away of twice the depth of the aborted hole or smaller distance if the aborted drill hole is filled with high strength mortar and if under shear or oblique tension load it is not in the direction of load application.
- Anchor installation such that the effective anchorage depth is complied with.
- Anchor expansion by impact on the cone (expansion pin) of the anchor.

R-DCA, R-DCA-A4 and R-DCL Wedge Anchors	Annex B1 of European Technical Assessment ETA-13/0584
Intended use Intended use	

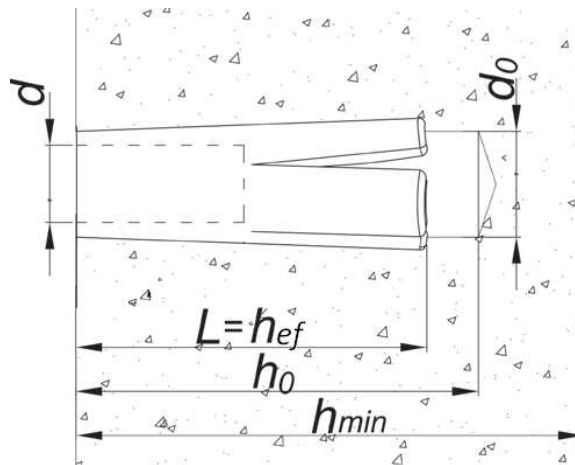

Table B1: Installation parameters

Anchor size	Effective anchorage depth	Drill hole depth	Drill hole diameter	Installation torque (max)	Thickness of concrete member (min)	Screwing depth (min)	Screwing depth (max)	Diameter of clearance hole in the fixture
	[mm]	[mm]	[mm]	[Nm]	[mm]	[mm]	[mm]	[mm]
	h_{ef}	h_1	d_0	$\max T_{inst}$	h_{min}	$l_{s, min}$	$l_{s, max}$	d_f
M6	25	30	8	4,5	80	6	11	7
M8	30	32	10	11	80	8	13	9
M10	40	42	12	22	80	10	15	12
M12	50	53	15	38	100	12	20	14
M16	65	70	20	98	130	16	25	18
M20	80	85	25	130	160	20	35	22

R-DCA, R-DCA-A4 and R-DCL Wedge Anchors

Intended use
Installation parameters

Annex B2
of European
Technical Assessment
ETA-13/0584

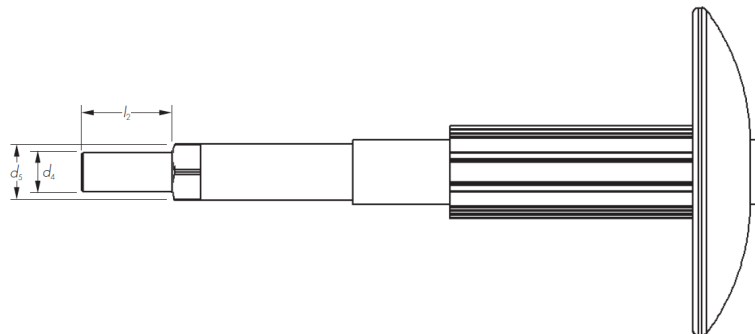
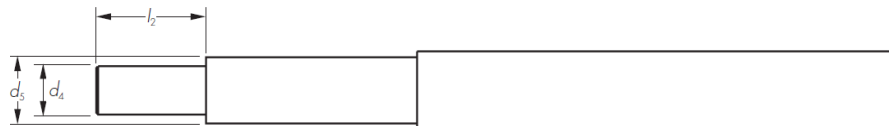
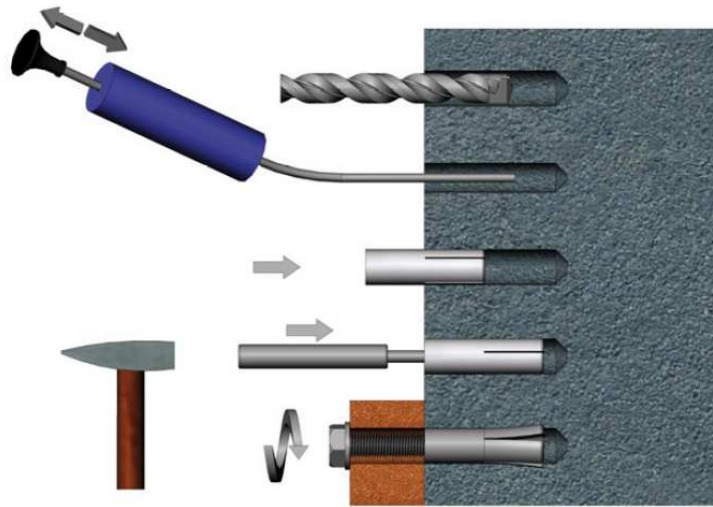

Installation tools		M6	M8	M10	M12	M16	M20
Diameter d ₄	[mm]	5,0	6,6	8,3	10,2	13,5	16,8
Diameter d ₅	[mm]	7,5	9,5	11,5	14,5	19,5	24,5
Length l ₂	[mm]	14,8	18,0	23,0	28,0	33,0	47,0

R-DCA, R-DCA-A4 and R-DCL Wedge Anchors

Intended use
Installation instruction

Annex B3
of European
Technical Assessment
ETA-13/0584

Table C1: Characteristic resistance - R-DCA and R-DCL (design acc. to ETAG 001, Annex C, method C)

R-DCA and R-DCL			Property class	M6	M8	M10	M12	M16	M20
All load directions (fastening screw or threaded rod property class ≥ 4.8)									
Characteristic resistance in cracked and non-cracked concrete C20/25 to C50/60	F_{Rk}	[kN]	≥ 4.8	1,52	3,01	4,57	6,43	13,31	17,38
Partial safety factor (installation safety factor $\gamma_2 = 1,4$ included)	γ_M^1	[-]	-	2,1					
Spacing	S_{cr}	[mm]		200				260	320
Edge distance	C_{cr}	[mm]		150				195	240
Shear load with lever arm									
Characteristic resistance	$M^0_{Rk,S}{}^2$	[Nm]	4.8	6	15	30	52	133	260
Characteristic resistance	$M^0_{Rk,S}{}^2$	[Nm]	5.8	8	19	37	66	167	325
Characteristic resistance	$M^0_{Rk,S}{}^2$	[Nm]	6.8	9	23	45	79	200	390
Characteristic resistance	$M^0_{Rk,S}{}^2$	[Nm]	8.8	12	30	60	105	267	520
Partial safety factor	γ_{Ms}^1	[-]	-	1,25					

¹ in the absence of other national regulations² characteristic bending moment $M^0_{Rk,S}$ for the equation (5.5) in ETAG 001, Annex C**Table C2:** Characteristic resistance - R-DCA-A4 (design acc. to ETAG 001, Annex C, method C)

R-DCA-A4			Property class	M6	M8	M10	M12	M16
All load directions (fastening screw or threaded rod property class A4-70)								
Characteristic resistance in cracked and non-cracked concrete C20/25 to C50/60	F_{Rk}	[kN]	A4-70	1,00	2,01	3,20	4,59	8,27
Partial safety factor (installation safety factor $\gamma_2 = 1,4$ included)	γ_M^1	[-]	-	2,1				
Spacing	S_{cr}	[mm]		200				260
Edge distance	C_{cr}	[mm]		150				195
Shear load with lever arm								
Characteristic resistance	$M^0_{Rk,S}{}^2$	[Nm]	A4-70	11	26	52	92	233
Partial safety factor	γ_{Ms}^1	[-]	-	1,25				

¹ in the absence of other national regulations² characteristic bending moment $M^0_{Rk,S}$ for the equation (5.5) in ETAG 001, Annex C**R-DCA, R-DCA-A4 and R-DCL Wedge Anchors****Performances**
Characteristic resistance**Annex C1**
of European
Technical Assessment
ETA-13/0584

Table C3: Characteristic resistance under fire exposure in concrete C20/25 to C50/60 – R-DCA and R-DCL (design acc. to ETAG 001, Annex C, method C)

Fire resistance class	R-DCA and R-DCL	M8	M10	M12	M16	M20	
All load directions (fastening screw or threaded rod property class 4.8)							
R30	Characteristic resistance $F_{Rk,fi}^1$	[kN]	0,4	0,9	1,6	3,1	4,3
R60		[kN]	0,3	0,8	1,3	2,4	3,7
R90		[kN]	0,3	0,6	1,1	2,0	3,2
R120		[kN]	0,2	0,5	0,8	1,6	2,5
Spacing	$S_{cr,fi}$	[mm]	4 x h_{ef}				
Edge distance	$C_{cr,fi}$	[mm]	2 x h_{ef}				
The design method covers anchors with a fire attack from one side only. In case of fire attack from more than one side, the edge distance shall be ≥ 300 mm.							

¹ in the absence of other national regulations a partial safety factor $\gamma_{m,fi} = 1,0$ is recommended

Table C4: Characteristic resistance under fire exposure in concrete C20/25 to C50/60 – R-DCA-A4 (design acc. to ETAG 001, Annex C, method C)

Fire resistance class	R-DCA-A4	M8	M10	M12	M16	
All load directions (fastening screw or threaded rod property class A4-70)						
R30	Characteristic resistance $F_{Rk,fi}^1$	[kN]	0,5	0,8	1,1	2,1
R60		[kN]	0,5	0,8	1,1	2,1
R90		[kN]	0,5	0,8	1,1	2,1
R120		[kN]	0,4	0,6	0,9	1,6
Spacing	$S_{cr,fi}$	[mm]	4 x h_{ef}			
Edge distance	$C_{cr,fi}$	[mm]	2 x h_{ef}			
The design method covers anchors with a fire attack from one side only. In case of fire attack from more than one side, the edge distance shall be ≥ 300 mm.						

¹ in the absence of other national regulations a partial safety factor $\gamma_{m,fi} = 1,0$ is recommended

R-DCA, R-DCA-A4 and R-DCL Wedge Anchors

Performances
Characteristic resistance under fire exposure

Annex C2
of European
Technical Assessment
ETA-13/0584